

**400A FIBER OPTIC INTERCONNECT
 UNIT (FOIU)
 INSTALLATION**

This instruction sheet covers the 400A1 (106266901) and 400A2 (106414170) Fiber Optic Interconnect Unit (FOIU). The 400A2 unit comes equipped with two locks. The 400A1 unit does not come equipped with locks but is provided with knockouts so that locks can be installed.

It is recommended that up to five 400A units be mounted in one column (Figure 1). The top of the first unit should be no more than 68 inches (1727 mm) above the floor. Space allocated for the installation of the 400A units should be 55 inches (1397 mm) high by as wide as required.

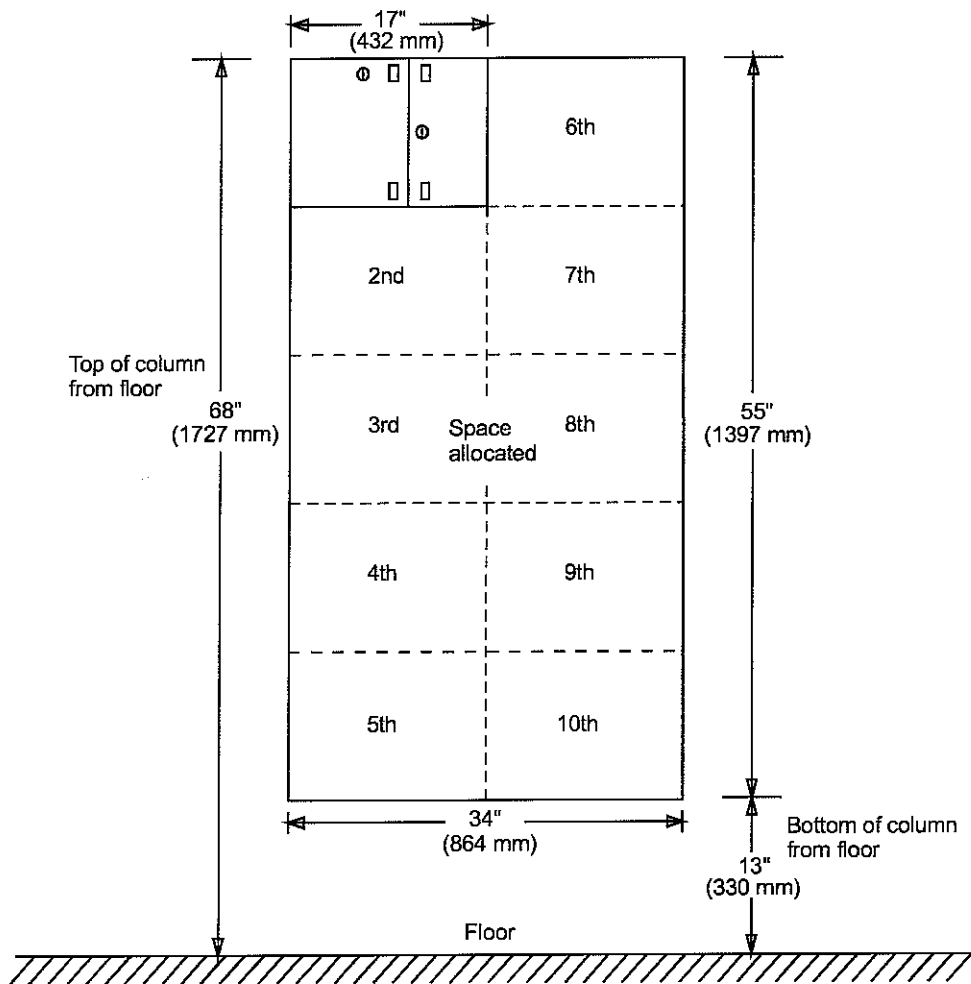

Figure 1—Recommended Mounting Configuration

STEP 1—INSTALL 400A Units

The mounting holes in the 400A unit are designed for easy installation with the top two mounting holes being keyholes. This allows the location of mounting screws to be marked, screws to be installed, and the 400A unit to be hung on the screws to be tightened down.

1. Position the 400A unit in upper left corner space allocated for installation.
2. Mark location of top mounting screws (Figure 2).
3. Remove 400A unit from wall.
4. Install two No. 8 wood screws or similar hardware for type of wall on which unit is being mounted.

Note: Install the screws only halfway.

5. Hang the unit on the two mounting screws.
6. Install the two bottom mounting screws.
7. Tighten all four screws.
8. Repeat Steps 1 through 7 for other units to be mounted.

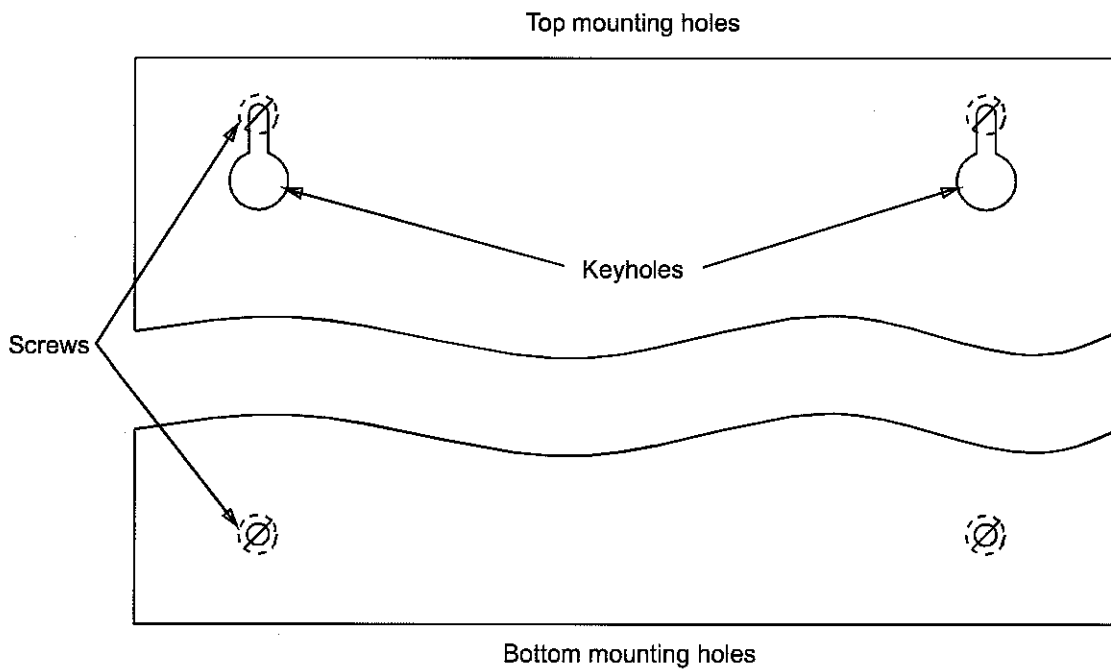

Figure 2—Mounting Holes

STEP 2—INSTALL 400A PARTS INSIDE OF UNIT

Install the following parts inside the 400A unit, before routing the cable inside the box.

Items to be install are as follows:

- Identification and notice decals
- Cable strain relief grommets (two provided)
- 12A1 or 12A2 cable clamps (must be ordered separately and installed two at a time)
- 1000-type panels (**ST**[®], SC, FC/DF, LC etc.) (must be ordered separately)
- Couplers or buildouts (must be ordered separately).

1. Install the provided identification and notice decals (Figure 3).
2. Remove the appropriate number of knockouts for cable entry.

Note: For cross-connect applications, cables are routed into the 400A unit on the left side. For interconnect applications, cables are routed on either side of the unit.

3. Install the cable strain relief grommets in the openings made by removing the knockouts (Figure 4).

Note: Grommets fit smaller knockouts only.

4. Remove the appropriate cable clamp bracket from the 400A unit.
5. Install two 12A1 or 12A2 cable clamps (Figure 6).

Note: The 12A-type cable clamps should be ordered and installed in pairs. See instruction sheet for applicable cable clamp.

6. Reinstall the cable clamp bracket with two 12A-type cable clamps (Figure 5).
7. Install couplers in 1000-type panels (Figure 6).

8. Mount individual identification decals on the panels and write the identification number of each coupler on the decals.

9. When the couplers have been installed, position and secure the panels onto the 400A bulk-head unit (Figure 7).

Note: The bulk-head unit partially slides in and out of the 400A unit allowing easy access to the couplers (Figure 5). The bulk-head will not slide out of the track completely.

STEP 2—INSTALL 400A PARTS INSIDE OF UNIT (Continued)

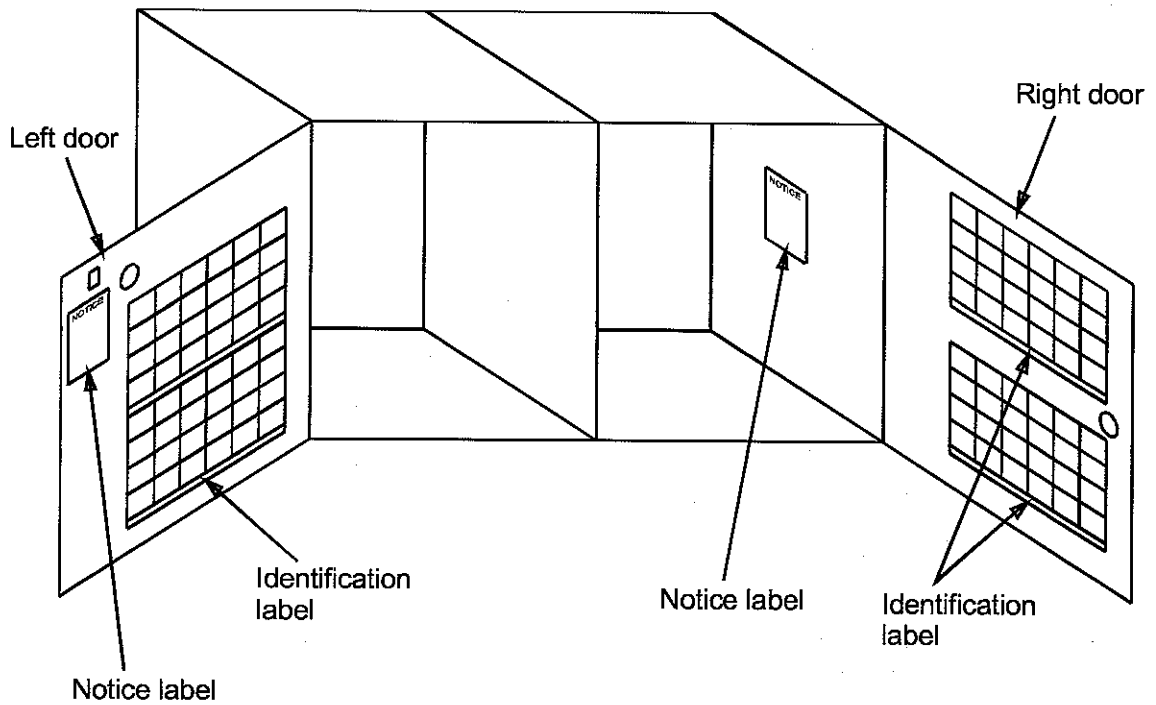

Figure 3—Decal Installation

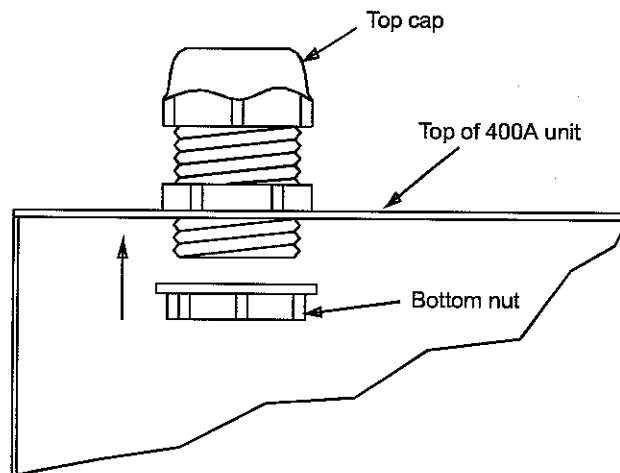

Figure 4—Cable Strain Relief Grommet

STEP 2—INSTALL 400A PARTS INSIDE OF UNIT (Continued)

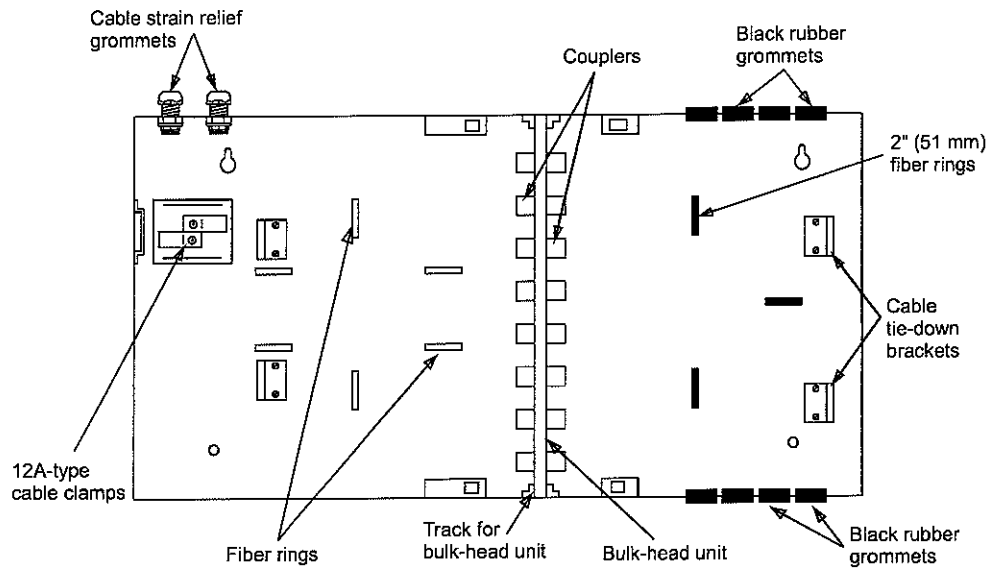

Figure 5—Parts Locations

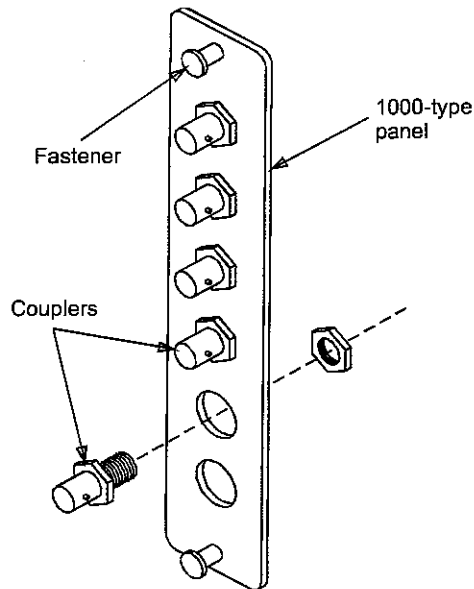

Figure 6—Coupler Installation (ST-Type Shown)

STEP 2—INSTALL 400A PARTS INSIDE OF UNIT (Continued)

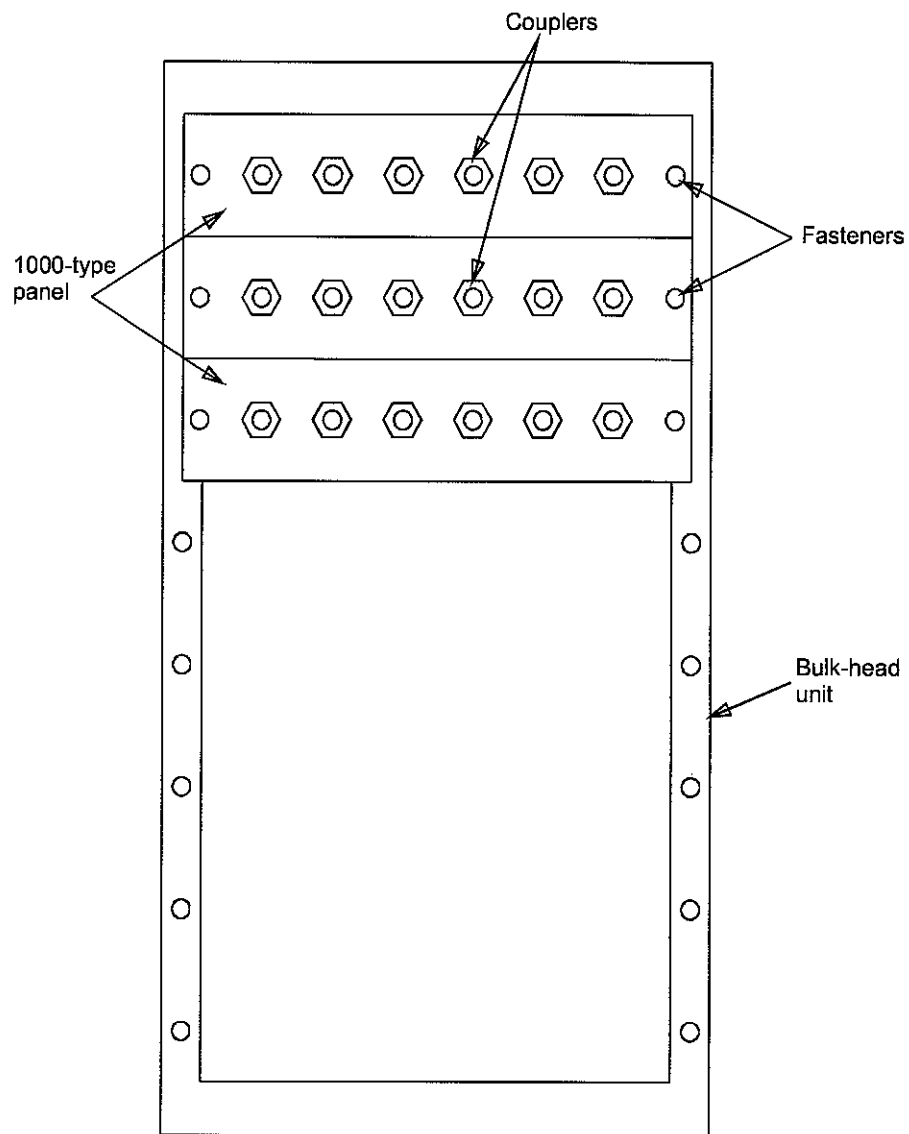

Figure 7—Bulk-Head Unit

STEP 3—ROUTE AND PREPARE CABLE INSIDE OF UNIT

Whether a cable is routed from the top or bottom of the 400A unit, a strain relief grommet should be installed in the first unit that the cable enters. The cable can then be clamped inside the individual unit. If a cable is to be routed from the first unit to a consecutive unit, the proper knockouts between the units must be removed.

1. Route cable through the cable strain relief grommet into the 400A unit (Figure 8).
2. Measure 60 inches (1524 mm) from the end of the cable back to the 12A-type cable clamp.
3. Mark and remove the sheath from the cable.
4. Attach the cable to a 12A-type cable clamp.
5. Tighten the top cap of the cable strain relief grommet.
6. Complete fiber termination by routing the fibers through protective tubing and installing the appropriate connectors on the individual fibers.
7. Repeat Steps 1 through 6 for all cables routed into the 400A unit.

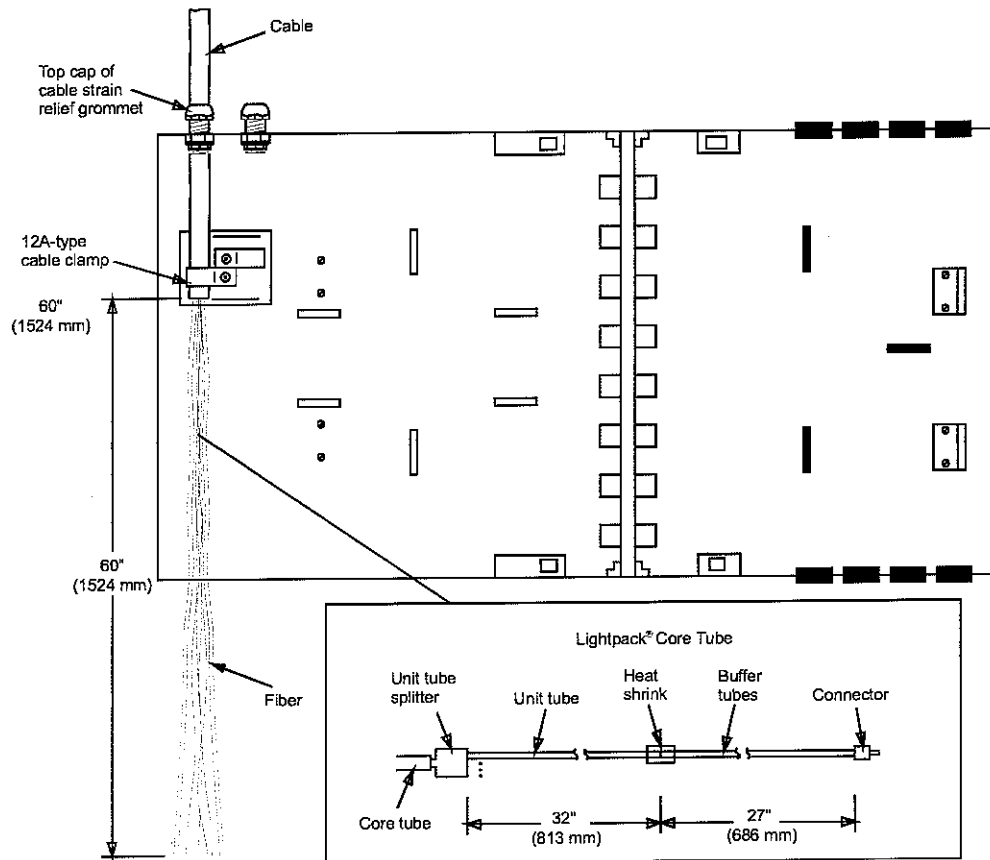

Figure 8—Cable Preparation

STEP 4—TERMINATE FIBERS AND STORE FIBER SLACK

After cable has been routed inside the 400A unit and connectors installed, the fibers may be terminated to the bulk-head unit.

1. Pull bulk-head unit out until it stops (Figure 9).
2. Terminate connectors to couplers on bulk-head unit.
3. Starting from the connector end of the fiber, store fiber slack inside the fiber rings.
4. When all fiber has been stored, slide bulk-head unit to the back of the 400A unit.
5. Close the 400A unit doors by first closing the left door and then closing the right door.
6. Turn plastic tabs to secure doors.

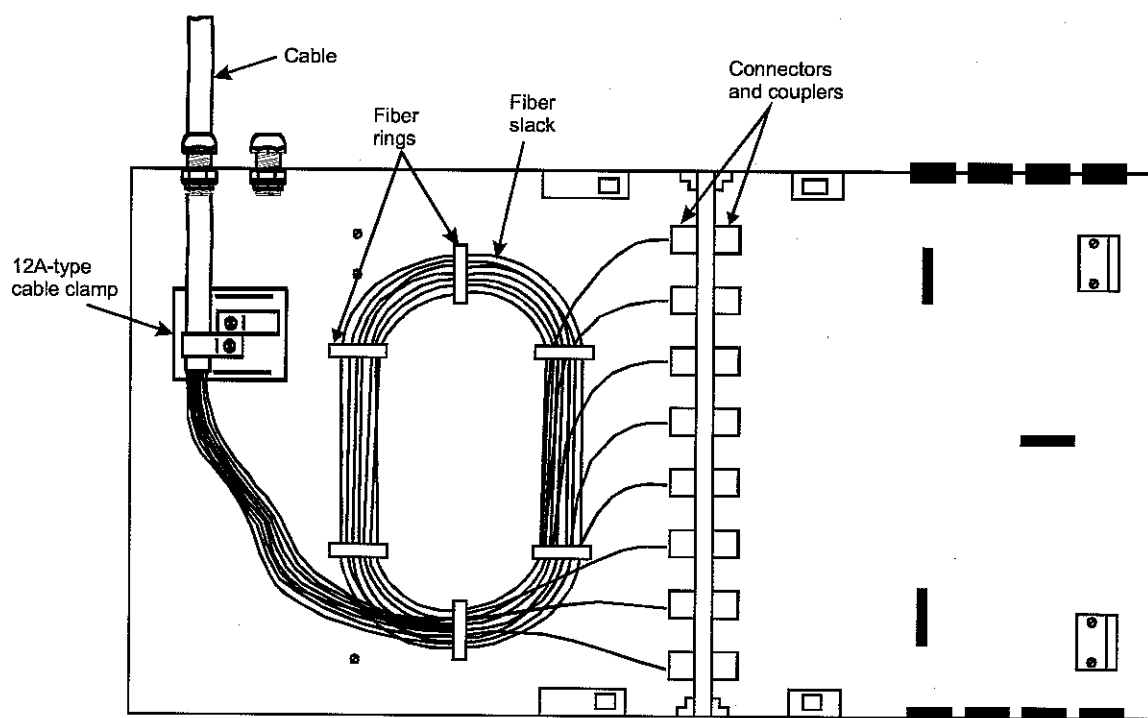

Figure 9—Cable Slack Storage

STEP 5—TERMINATE AND ROUTE JUMPERS

The jumpers are located on the right side of the 400A unit and can be routed to the next unit through the black grommets.

1. Pull bulk-head unit out until it stops (Figure 10).
2. Terminate jumpers to couplers on bulk-head unit.
3. Slide bulk-head unit to the back of the 400A unit.
4. Prepare black grommets by using a utility knife to cut grommets along dotted lines.
5. Route jumpers through black grommets and terminate in the desired unit.
6. Store the jumper slack in the fiber rings.
7. Close the 400A unit doors by first closing the left door and then closing the right door.
8. Turn plastic tabs to secure doors.

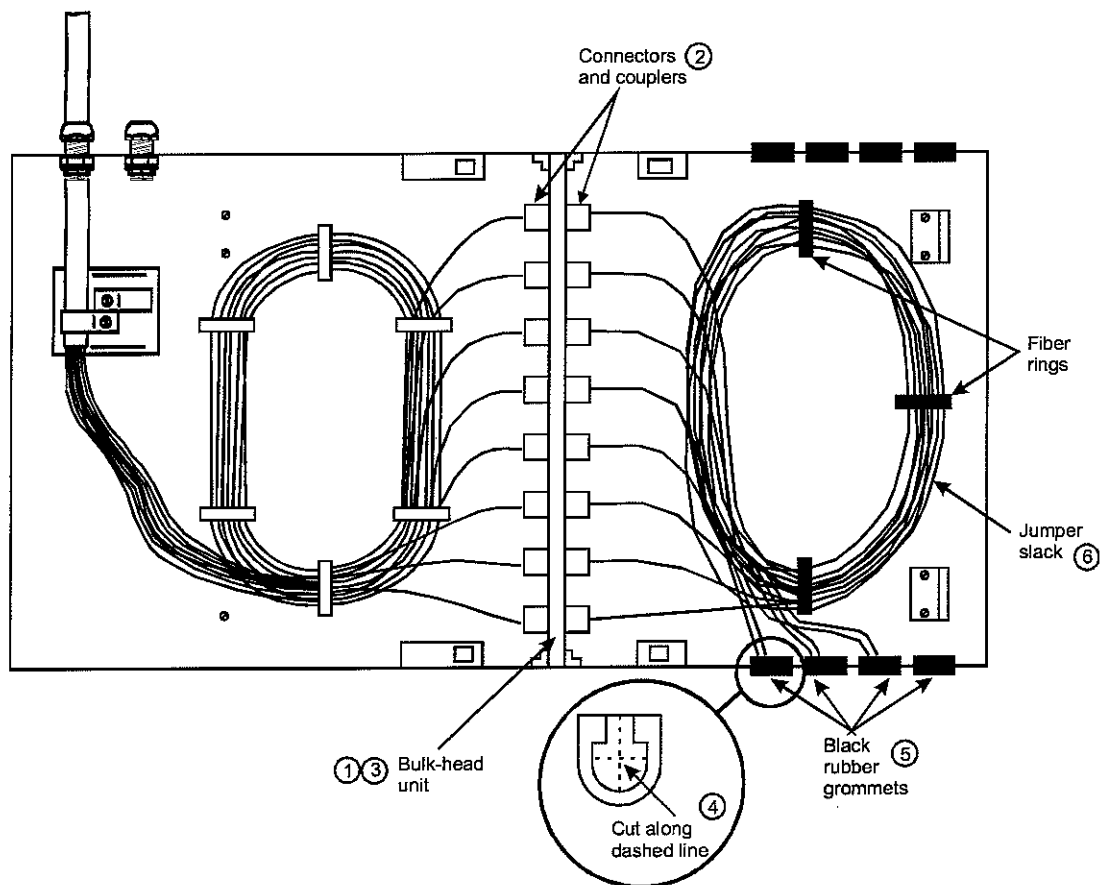

Figure 10—Jumper Slack Storage

636-299-109-01
Instruction Sheet

STEP 6—INTERCONNECTION APPLICATION

The 400A unit will accommodate interconnection of OSP cables to building cables.

1. Remove knockout for cable entry from the right side of the 400A unit (Figure 11).
2. Install cable strain relief grommet in the knockout opening.
3. Route the building cable through the grommet.
4. Tie wrap the cable to the top tie down bracket and tighten top cap of cable strain relief grommet.
5. Measure 40 inches (1016 mm) from the end of the cable back to the tie down bracket.
6. Remove 38 inches (965 mm) of jacket from the cable.
7. Install a connector on each fiber and terminate the connectors to the couplers on the bulk-head unit.
8. Starting from the connector end of the fiber, store fiber slack inside the fiber rings.
9. When all fiber has been stored, close the 400A unit doors by first closing the left door and then closing the right door.
10. Turn plastic tabs to secure doors.

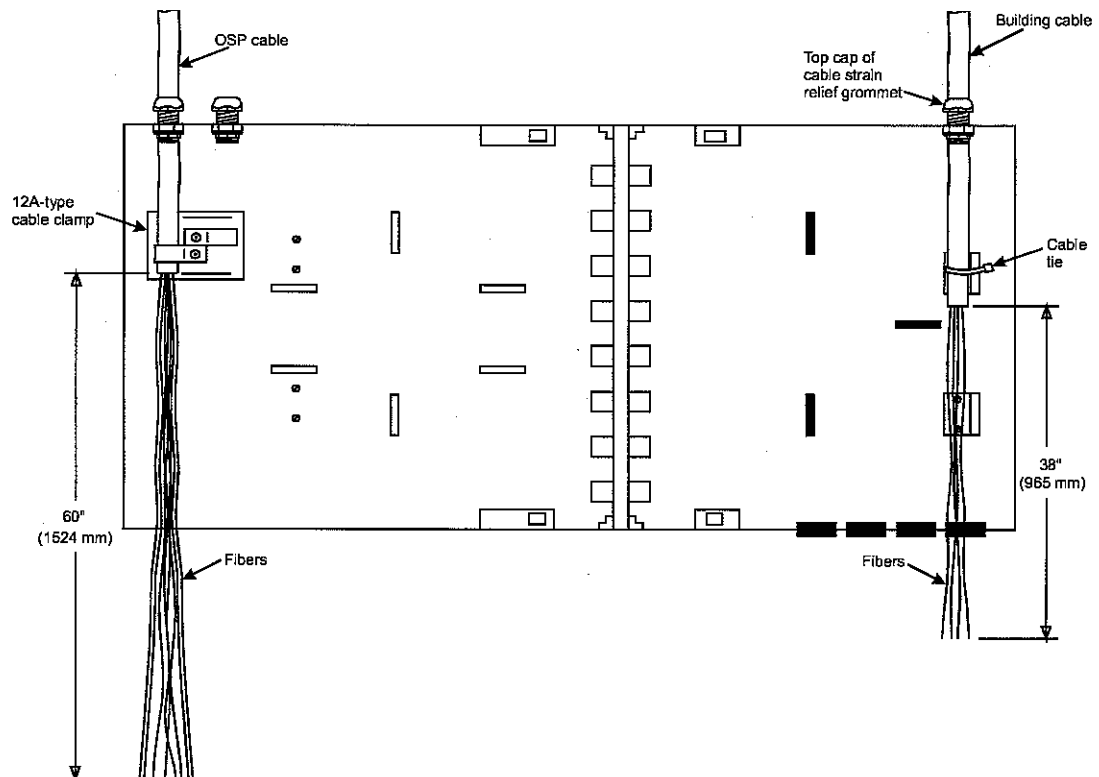
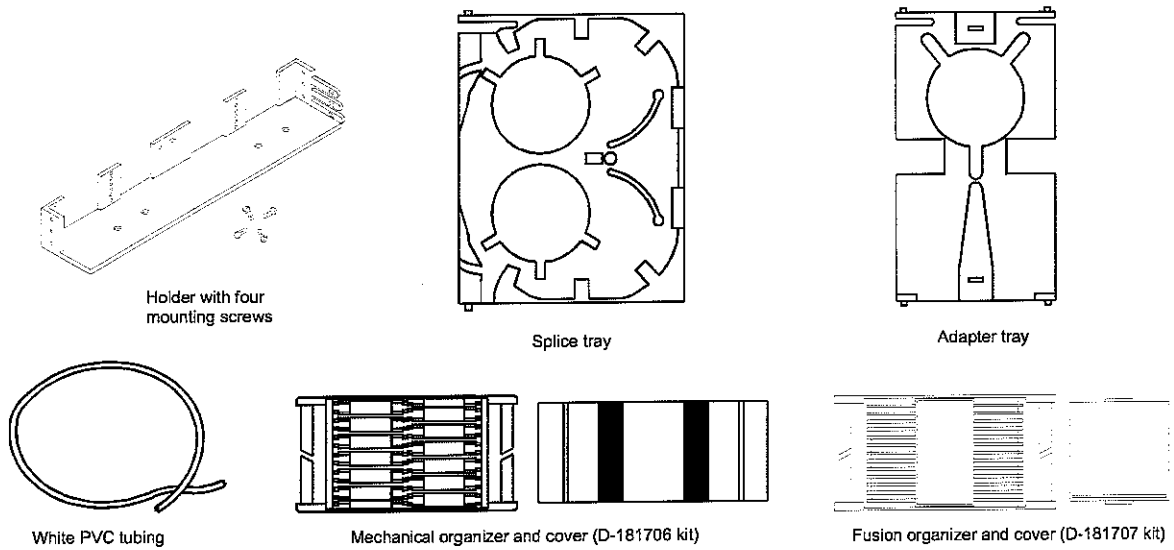

Figure 11—Interconnection Cabling

**D-181706 FIBER OPTIC MECHANICAL/ROTARY SPLICE ADAPTER KIT AND
D-181707 FIBER OPTIC FUSION SPLICE ADAPTER KIT FOR 400A UNIT INSTALLATION**

STEP 1—VERIFY APPLICABLE KIT MATERIALS



STEP 2—REMOVE METAL BRACKETS AND PLASTIC RINGS

Note: If the 400A unit does not contain the six plastic split rings or metal bracket, go to Step 3.

1. Remove and discard the six plastic split rings.
2. Remove and discard the two metal brackets.

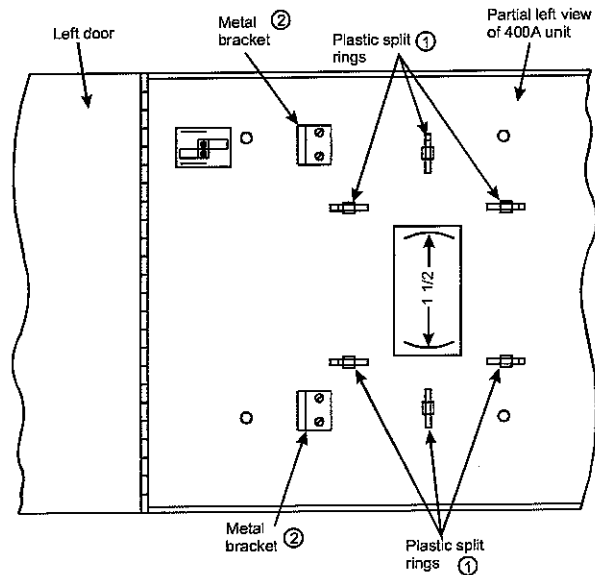

STEP 3—INSTALL HOLDER

1. Locate the holder and four mounting screws.
2. Position the holder in the 400A unit and secure with the four mounting screws.

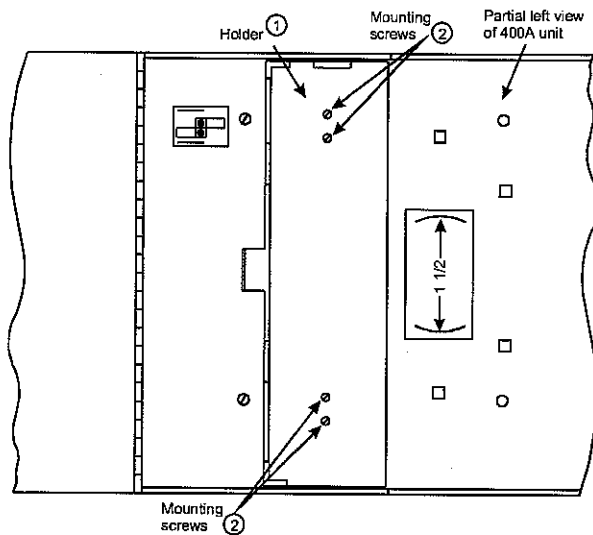

STEP 4—INSTALL SPLICE TRAY

1. Locate the splice tray and note the mounting tabs on upper and lower left edge of the tray.
- Note:** The upper mounting tab is spring-loaded.
2. Insert the lower tab of the tray into the lowest hole of the holder's bottom mounting flange.
 3. Press down on the tray's upper spring-loaded tab and insert it into the lowest hole on the holder's top mounting flange.

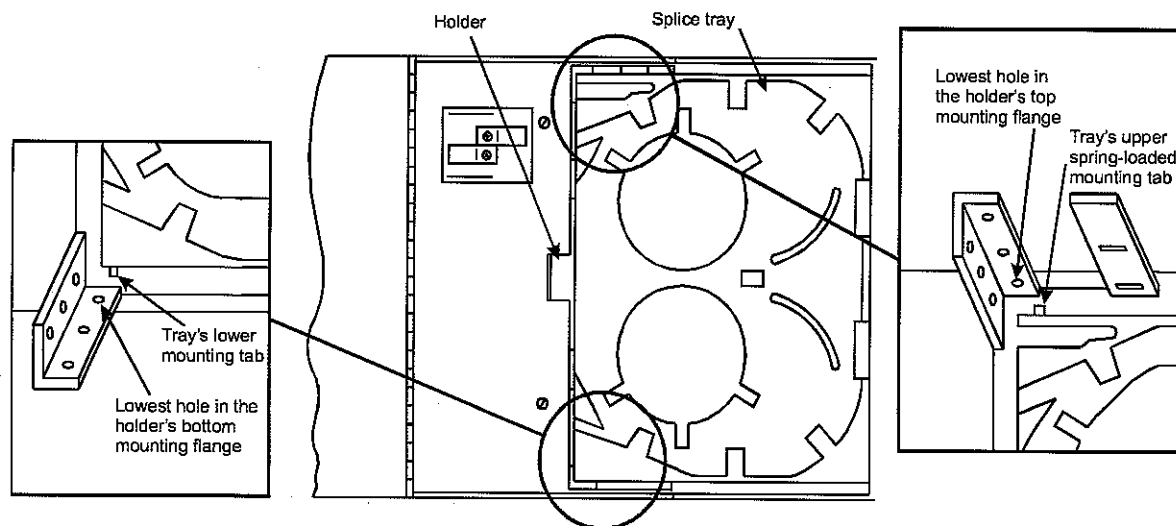

STEP 5—PREPARE AND INSTALL CABLE

1. Prepare the end of the lightguide cable.

Note: Allow for 60 inches (1524 mm) of cable fiber slack and leave ½ inch (13 mm) of inner tubing from the cable sheath.

2. Install the lightguide cable in the 12A-type clamp and ground the cable, if required.
3. Cut a length of the white PVC tubing long enough to reach from the cable end to 1 inch (25 mm) inside the splice tray's entry slot.
4. Insert a maximum of 12 fibers into the cut length of PVC tubing and slide the tubing up over the fibers to the butt of the cable.
5. Place the PVC tubing into the splice tray's entry slot.

Note: The tubing must extend 1 inch (25 mm) into the entry slot.

6. Install splice organizer onto the splice tray by inserting the organizer under the tray's two outer mounting tabs, then gently pressing the opposite side of the organizer under the tray's inner mounting tab.

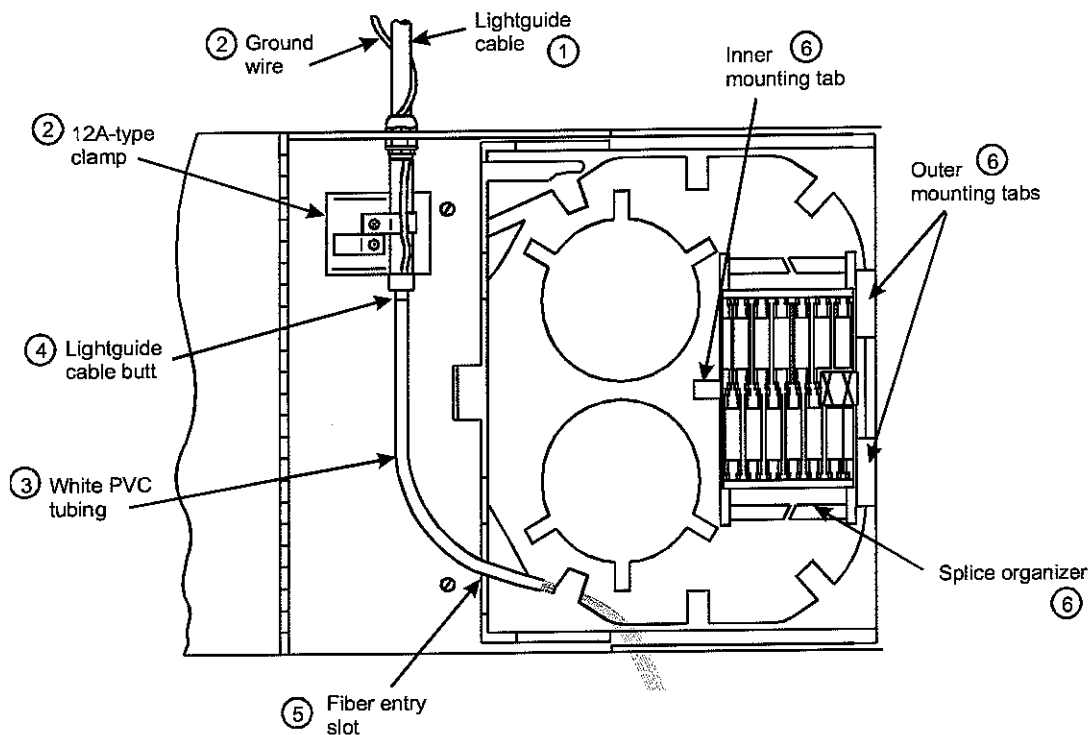

636-299-109-01
Instruction Sheet

STEP 6—STORE FIBER SLACK

1. Splice the fiber pigtails and cable fibers.
2. Store the completed splices in the splice organizer and install the organizer cover.
3. Starting at the PVC end of the cable fiber, wrap the fiber around the lower storage cylinder of the splice tray in a counterclockwise direction.
4. Starting at the splice end of the pigtails, store two slack loops around the upper storage cylinder of the splice tray in a counterclockwise direction.
5. If a second splice tray is to be added to the 400A unit, repeat Steps 4 through 6.

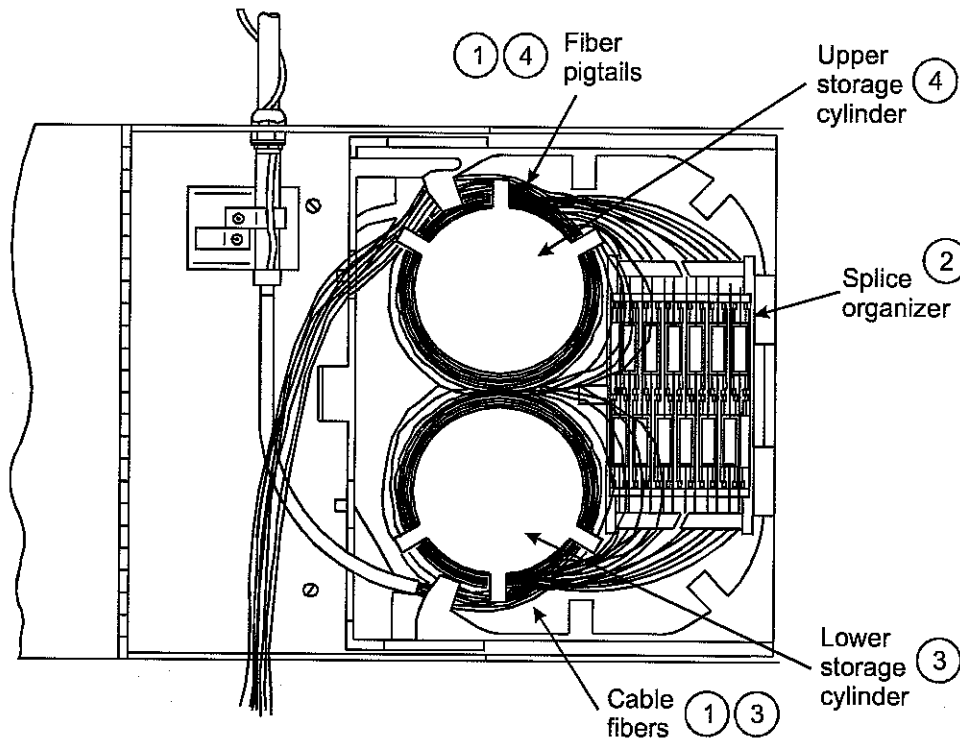

STEP 7—INSTALL ADAPTER TRAY

1. Locate the adapter tray and note the mounting tabs on upper and lower left edge of the tray.

Note: The upper mounting tab is spring-loaded.

2. Route all pigtail fibers through the adapter tray's left opening.
3. Insert the lower tab of the adapter tray into the lowest hole of the holder's bottom mounting flange.
4. Press down on the tray's upper spring-loaded tab and insert it into the lowest hole on the holder's top mounting flange.

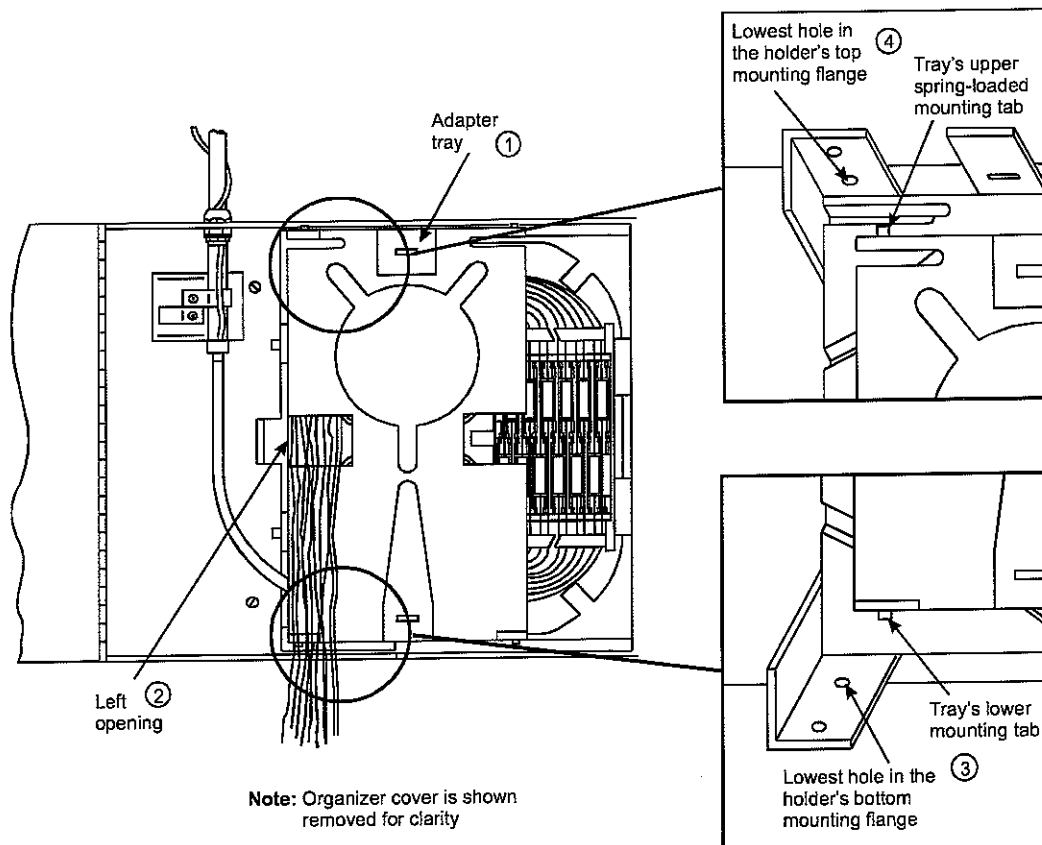

STEP 8—STORE PIGTAIL FIBER SLACK

1. Store the pigtail fiber slack around the adapter tray's storage cylinder in a counterclockwise direction.

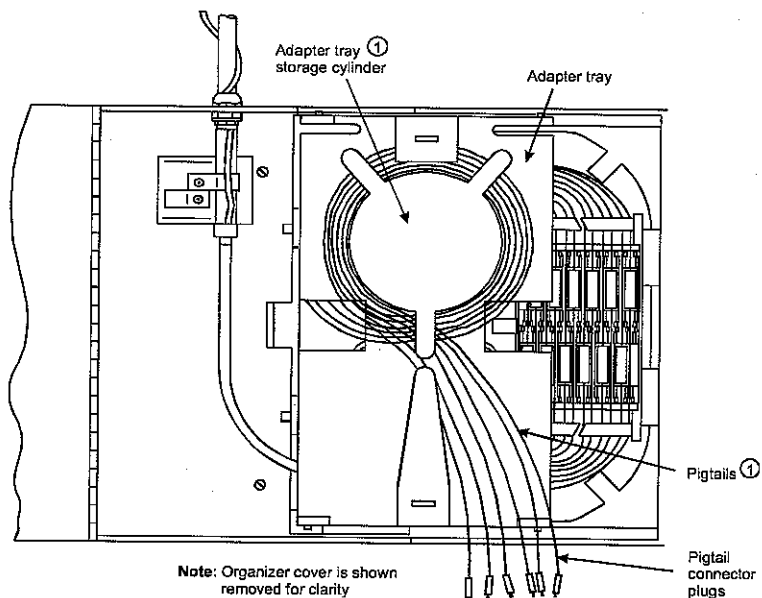

STEP 9—INSTALL CONNECTOR PANELS AND CONNECT PIGTAIL CONNECTOR PLUGS

1. Install connectors on the connector panel in only the first three positions.
 2. Install 1000-type connector panels into 400A unit.
- Note:** Make sure the connectors are toward the front of the 400A unit.
3. Connect the pigtail connector plugs to the connector panels.

